

SOFT SWITCHING OF INTERLEAVED BOOST CONVERTER FED PMBLDC MOTOR USING PI AND FUZZY CONTROLLERS

V. RAMESH¹, Y. KUSUMA LATHA²

¹Research Scholar & Student Member IEEE, Department of Electrical & Electronics Engineering, K L University, Guntur, A.P, India. E-Mail: sitamsramesh@gmail.com

²Professor, Department of Electrical and Electronics Engineering, K L University, Guntur, A.P, India
E-Mail: kusumalathayp@gmail.com

O. CHANDRA SEKHAR³

³Professor, Department of Electrical and Electronics Engineering, K L University, Guntur, A.P, India
E-Mail : sekharobbu@kluniversity.in

Abstract:

This paper proposes an improved interleaved boost converter topology for soft switching of VSI fed PMBLDC motor. Six switch and four switch converter configurations are employed for the proposed boost converter under Zero voltage switching and Zero current switching. The proposed boost converter for PMBLDC motor under various operating condition are implemented in MATLAB/SIMULINK environment. The feasibility of six switch and four switch converter by for PMBLDC motor is explored. A comparative evaluation of speed control of six switch and four switch inverter with fed PMBLDC motor PI and FUZZY controllers has been made discussed in this paper.

Key words: Four switch VSI, Fuzzy logical control, PI, PMBLDC Motor, Six switch VSI.

1. Introduction

High frequency switching in converter results in reducing losses, the traditional boost converter will employ Zero voltage and Zero current switching. In the past numerous soft switching methods are developed for boost converters [1]-[2]. The Zero voltage switching (ZVS) and Zero current switching (ZCS), strategy the losses due to switching are reduced in the main switch. Therefore, the efficiency of ZVS or ZCS based topology is improved compared to conventional topology [3]-[4].

In the past, numerous soft switching methods are developed for boost converters. The losses due to soft switching are reduced in case of Zero voltage switching (ZVS) and Zero current switching (ZCS) topologies and efficiency is improved compared to the conventional converter [4]-[5]. PMBLDC motor many advantages when compared with other type of AC motors [6]-[7]. Torque ripple in PMBLDC motor may be related to inverter or motor design factors of the motor, which results non ideal current waveforms, this causes speed oscillations and wear and tear of mechanical portions of the drive, which

results in vibration and noise of the motor[8]. The soft switching techniques reduce the switching voltage stress of the main switches of the converter. This topology has some advantages which Include low cost, reduction in switching losses, improved efficiency [9]-[10]. Speed control of a drive refers to maintaining constant speed, with any variation of electric power [11]-[12]. The purpose of speed control is to maintain constant speed and to make it less sensitive external disturbances [13]. There are many method of speed Control, among them PI controller is most common and FUZZY controller most flexible controller[14]-[15]. PI is used is numerous industrial applications while fuzzy control robust and possess noise rejection capabilities.

In this paper, comparison has been made between PI and Fuzzy controller interleaved boost converter based VSI fed PMBLDC motor drive. Here, four switch and six switch converter continuous are considered for VSI and proposed work in carried out for different operating conditions and simulation results are presented to validate the proposed work.

2. Proposed Control Schemes of Interleaved boost converter with ZVS and ZCS fed PMBLDCM Drive

2.1. Interleaved boost converter with ZVS and ZCS for Six switch three phase VSI fed PMBLDC Motor

Fig.1 shows the block diagram of Interleaved Boost Converter with ZCS and ZVS fed BLDC motor. There are two control loops; one is the speed control loop which is outer loop and another inner current loop. The speed error obtained by comparing the actual speed with the desired reference speed. The speed error is fed to the PI and Fuzzy logical controller to obtain the reference torque and compared with actual torque of PMBLDC Motor.

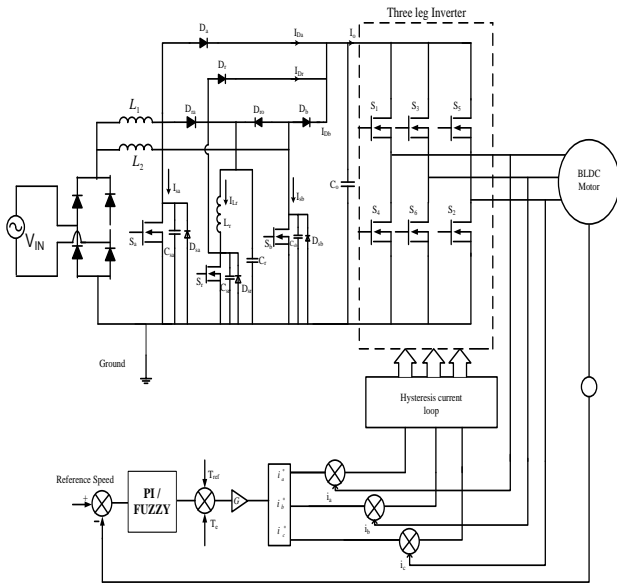

Fig.1: Interleaved boost Converter with ZVS and ZCS for six switch three phase VSI fed PMBLDC Motor

The resultant torque error is multiplied with suitable constant and is amplified to provide input to reference current block. The reference current is compared with phase currents of PMBLDC Motor which is fed to hysteresis current controller. The hysteresis current controller generates pluses for operation of three leg inverter of PMBLDC Motor drive. A rate limiter is introduced, which limits the current within specified limits.

2.2. Interleaved Boost Converter with ZVS and ZCS for Four Switch Three Phase VSI fed PMBLDC Motor

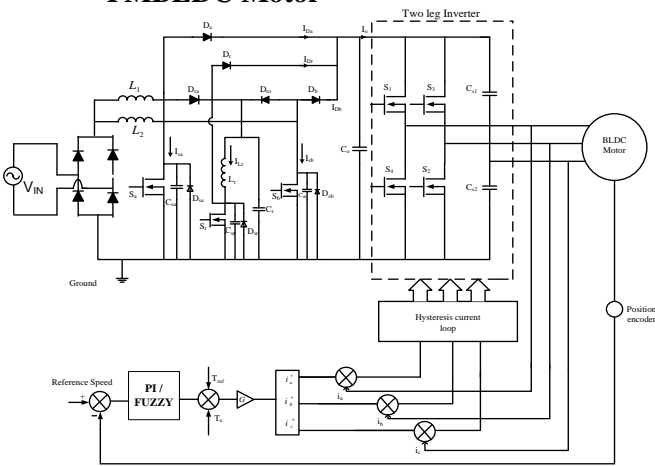

Fig.2: Interleaved boost Converter with ZVS and ZCS for four switch three phase VSI fed PMBLDC Motor

Fig.2 shows the closed loop speed control of four switch three Phase Inverter fed PMBLDCM drive with interleaved boost converter. Fig 2.shows the three phase inverter four switch fed BLDC motor with interleaved Boost Converter. With closed loop mode of speed control. The motor of speed control is advantageous because of low cost (2 -capacitor and only 4 -switches are utilised) and Lower losses during switching operation. The faster dynamic response of drive reduces ripples in toque, lower voltage stress and increase in the overall performance of the system.

2.3. Interleaved Boost Converter

Fig3.The circuit consists of inductor L_r , capacitor C_r , which are the resonance elements along with C_{sa}, C_{sb} which represent the parasitic capacitances. In order to achieve ZVS, ZCS characteristics, the current consists of S_r , auxiliary switch to aid the phenomenon of resonance. The components of interleaved boost converter are described in.

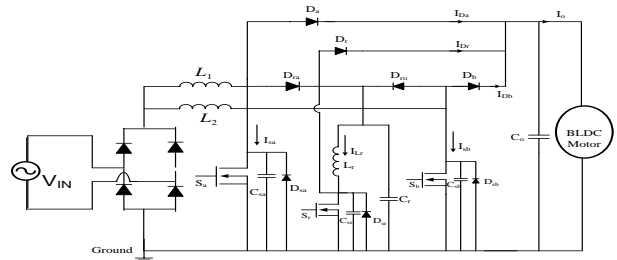

Fig3. Circuit for Interleaved boost converter

High voltage gain DC boost converter that proposed in this paper is a combination of two 2 phase interleaved boost converters and is shown by Fig.2. The four power electronic based switching devices used in the Fig.2 are controlled in 90° to each other's simultaneously (interleave technique method), in order to smooth output ripple current, raising power rating and efficiency. For the Fig.3, from KVL, voltage equation is given by equation(1)

$$V_0 = V_{sa} + V_{sb} - V_{in} \quad (1)$$

Where, V_s = Supply voltage ,

V_0 = Output voltage,

V_{sa} = Voltage across Capacitor " C_a ",

V_{sb} = Voltage across Capacitor " C_b "

Voltage gain (G) for the fig.2 is given by equation (2)

$$G = \frac{V_o}{V_s} = \frac{1+D}{1-D} \quad (2)$$

Where, D = Duty cycle ,

In the proposed high voltage gain interleaved DC boost converter, there is a considerable reduction in input current ripple and inductor size. The output voltage ripple of the circuit depends on the size of capacitor. The proposed converter should be operated in Continuous Conduction Mode (CCM). Based on the equations (3) & (4), the inductance & capacitance values respectively can be decided for the proposed converter.

$$L = \frac{DV_s}{4\Delta I_L f_s} \quad (3)$$

$$C_{bus} = \frac{DI_{out}}{2\Delta V_{bus} f_s} \quad (4)$$

Where, ΔI_L = Maximum current ripple

ΔV_{bus} = Output voltage ripple

I_{out} = Output current f_s = Switching

frequency for the proposed converter.

Here the study of the Interleaved boost converter PMBLDC Motor is operated in the PI and FUZZY

2.4. Fuzzy Logical Controller

The conventional PI controllers are fixed-gain controllers i.e., the proportional and integral gains are constant. So, this type of controllers will not compensate properly, if the parameter changes and it does not adjust with changes in environment. The response of the PI-controller is too slow due to its sluggish response to relatively prompt variations in the state which will result more settling time. In addition to finding the gain constants related to system is very difficult. Therefore the fuzzy control algorithm is capable of improving the system performance as compared with the classical methods. The two FLC input variables are the electromagnetic torque and change of electromagnetic torque. The operation of a fuzzy logic controller depends on the shape of membership functions for rule base.

In this paper a fuzzy logic control scheme (Fig 1 & Fig 2) is proposed for speed control of an PMBLDC motor. The fuzzy logic controller has advantages to be robust and relatively simple to design. The irrespective of system exact model we can able to design fuzzy logic controller. The fuzzy rule based approach is done through three stages. They are Fuzzification, inference engine and defuzzification.

2.5. Fuzzification

Fuzzy logical controller is an advanced controlled using multi valued logical. It is works on the principle of rule based system. It involves two processes namely fuzzification and defuzzification. Fuzzification involves the process of transforming a constant value into linguistic variable while defuzzification deals with hienstic variable conversion to constant value. In other words defuzzification is the inverse process of fuzzification of each input in graphical form. bell shaped is most common used membership function. Fuzzy logic is employed in speed Control with error in speed (error), the rate of change of speed (error),

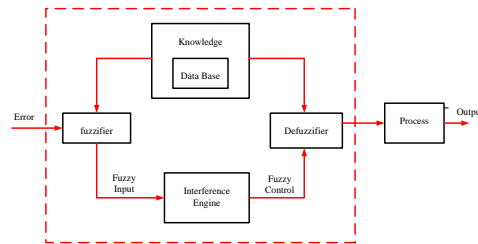

Fig4: Block diagram of fuzzy logic controller

Fig4:shows the basic block diagram of fuzzy logic controller (FLC)

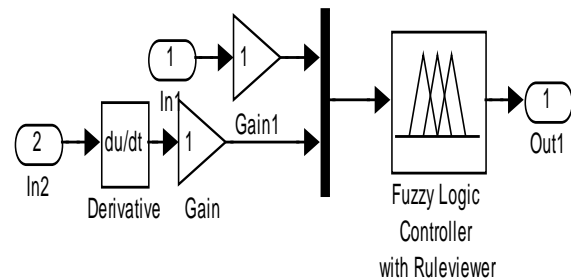

Fig5: Simulink diagram of fuzzy logical control

Fig5.simulink diagram implementation of Fuzzy logic controller(FLC). The two inputs namely error and error fed FLC. The input is also change in speed and derivative terms is added to get rate of change of speed. The rule based system is incorporated is simu link block of fuzzy logic controller. The member ship function considered here triangular shape.The following are various linguistic terms for the FLC

- Negative Big (NB)
- Negative Medium(NS)
- Zero (Z)
- Positive Medium (PM)
- Positive Big (PB)

After assigning the input, output ranges to define fuzzy sets, mapping each of the possible seven input fuzzy values of speed deviation, active power deviation to the seven output fuzzy values is done through a rule base. Thus the Fuzzy. Associative Memory (FAM) comes into picture (Fig6, Fig7, Fig 8).

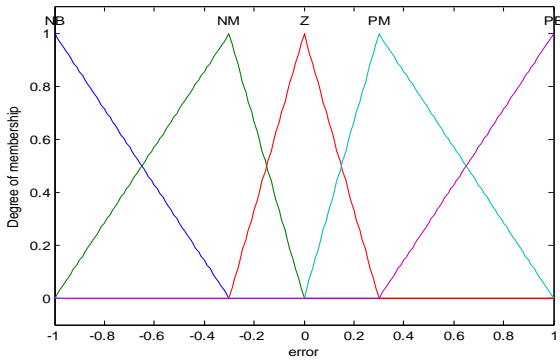

Fig6: Membership functions for error and change in 'error'

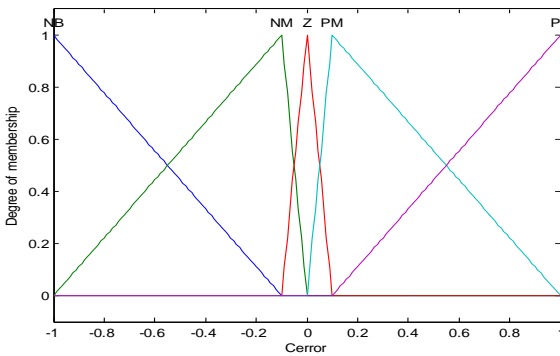

Fig7: Membership functions for error and change in 'error'

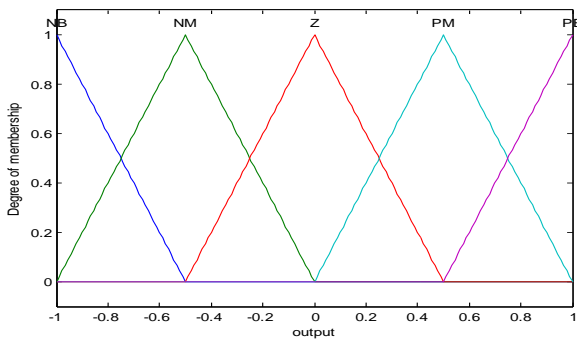

Fig8: Shows the membership function of output variable

Fig.6and Fig.7.shows input membership function i.e for error and change in error and cerror. Fig8 shows member ship function of the output variables.

Table -1

Rule base for Fuzzy Controller for 6- switch 4-switch three phase VSI fed Fuzzy speed control drive PMLDLC motor

Error/cerror	NB	NM	ZO	PM	PB
NB	NB	NB	NB	NM	Z
NM	NB	NB	NM	Z	PM
ZO	NB	NM	Z	PM	PB
PM	NM	Z	PM	PB	PB
PB	Z	PM	PB	PB	PB

Rules base:

1. If error in NB and cerror is NB, output is NB
2. If error is NB and c error is NM, output is NB
3. If error is NB and cerror is Z ,output is NB
4. If error is NB and cerror is PM ,output NM
5. If error is NB and cerror is PB,output Z

Similarly the remaining other rules are written in similar fashion .which are tabulated in Table-1.

2.6. Design of PMLDLC Motor

A PMLDLC Motor has three stator phase windings connected in a star manner. Fig 9:shows the equivalent circuit of a PM BLDC Motor.

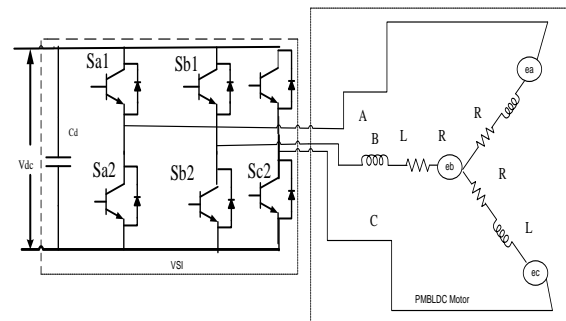

Fig9: Shows the equivalent circuit

The windings of a BLDC Motor modelled as a series combination of RL and speed depends on the voltage source, which is known as the back EMF .The BLDCM has three phases and those phase

voltages are given by the equations

$$V_{ao} = Ri_a + L \frac{di_a}{dt} + e_a + V_{no} \quad (5)$$

$$V_{bo} = Ri_b + L \frac{di_b}{dt} + e_b + V_{no} \quad (6)$$

$$V_{co} = Ri_c + L \frac{di_c}{dt} + e_c + V_{no} \quad (7)$$

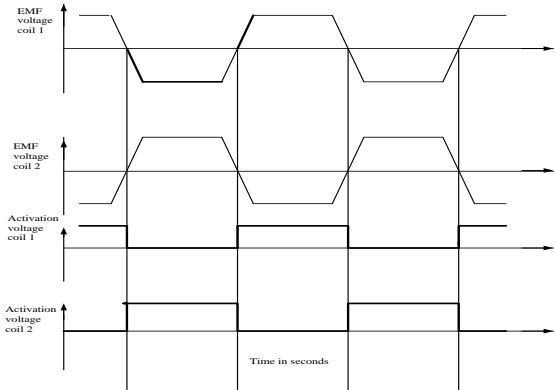

Fig10: PMBLDC Motor Waveforms of ideal back EMF and phase current

Equation(5) & (6) & (7) Where, V_A Voltage of phase 'A', V_B Voltage of phase 'B', V_C Voltage of phase 'C', I_A Current of phase 'A', I_B Current of phase 'B', I_C Current of phase 'C', R = Stator resistance, e_a = Phase "A" stator flux linkages, e_b = Phase "B" stator flux linkages, e_c = Phase "C" stator flux linkages, e_a = Phase "A" back EMF, e_b = Phase "B" back EMF, e_c = Phase "C" back EMF.

Fig10: Shows the relationship between the back EMF waveform of an ideal PMBLDC Motor and the armature current. The shape of the currents should be in rectangular waveform and must be in phase with the corresponding phase back EMF in Table-2

If the self and mutual inductance around the air gap are consider to be constant, then there will be a direct relation between the applied source voltage to the phase terminals (V) and the induced back EMF (E) is given by equation(10) and the electromagnetic torque (T_e) in N.M is given by equation (11).

$$W_e(n) = W_r(n)^* - W_r(n) \quad (11)$$

The new value of torque reference is given by

$$T(n) = T_{(n-1)} + K_p W_e(n) - W_e(n-1) + K_i W_e(n) \quad (12)$$

Where, W_e = Rotor mechanical speed.

Table -2 VSI switching sequence based on the Hall Effect sensor signals

Ha	Hb	Hc	Ea	Eb	Ec	S1	S2	S3	S4	S5	S6
0	0	0	0	0	0	0	0	0	0	0	0
0	0	1	0	-1	+1	0	0	0	1	1	0
0	1	0	-1	+1	0	0	1	1	0	0	0
0	1	1	-1	0	+1	0	1	0	0	1	0
1	0	0	+1	0	-1	1	0	0	0	0	1
1	0	1	+1	-1	0	1	0	0	1	0	0
1	1	0	0	+1	-1	0	0	1	0	0	1
1	1	1	0	0	0	0	0	0	0	0	0

3. Results and Discussion

3.1. Interleaved Boost Converter with 6- switch and 4- switch three phase VSI fed speed control of PI and Fuzzy logical control PMBLDC motor drive

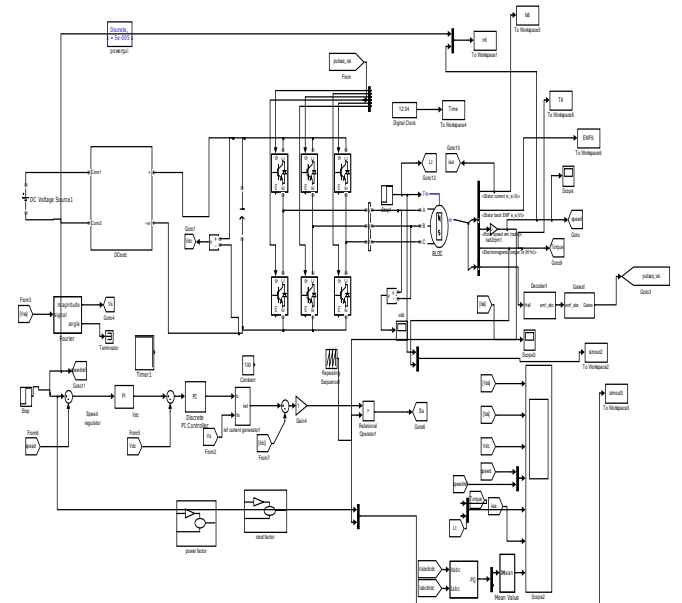

Fig 11(a): Simulation diagram of with PI controller

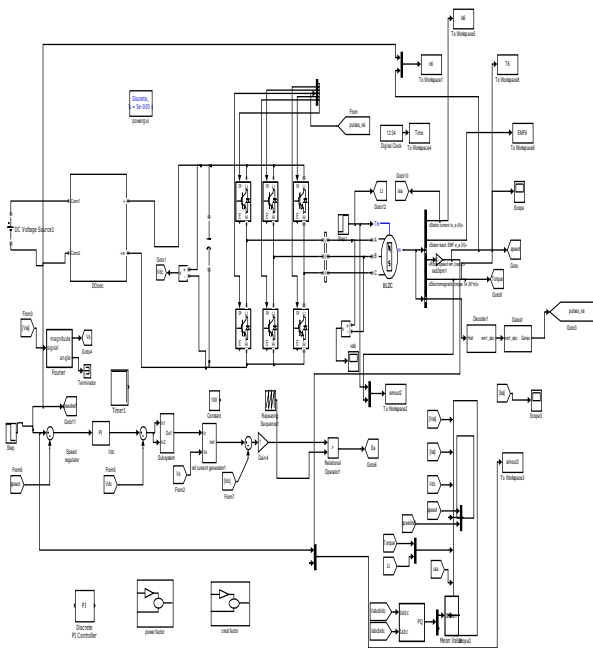

Fig 11(b): Simulation diagram of Fuzzy logical control

Fig11: Simulink diagram for speed control of interleaved boost converter based 6- switch three phase VSI fed PMLBDC Motor employing PI and Fuzzy control

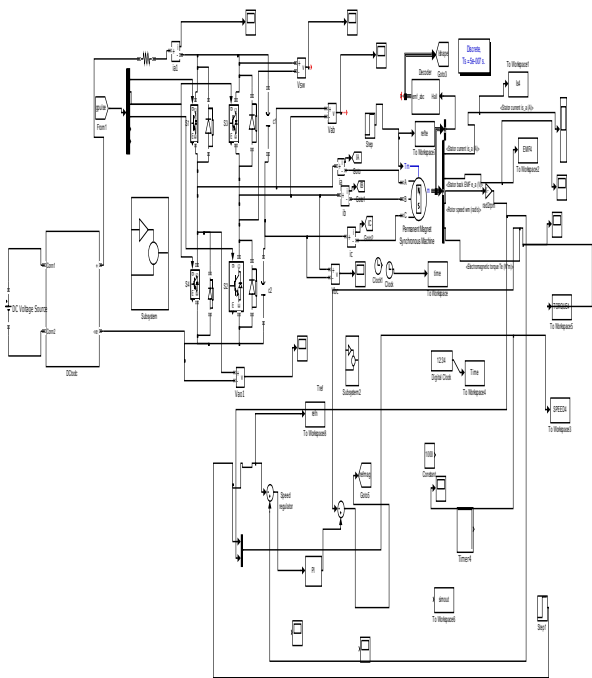

Fig 12(a): Simulation diagram of with PI controller

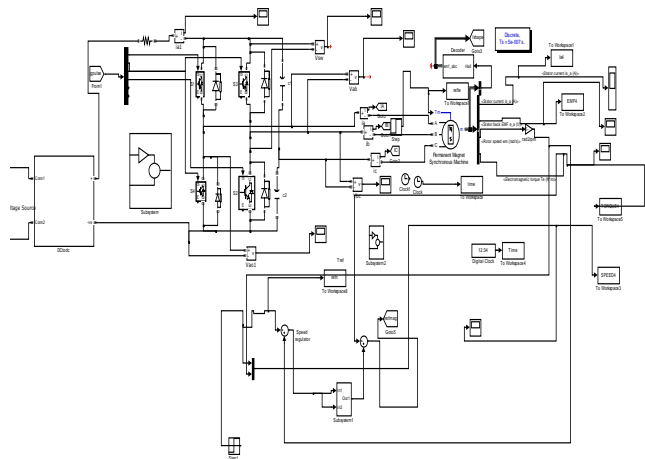

Fig 12(b): Simulation diagram of Fuzzy logical control

Fig12: Simulink diagram for speed control of interleaved boost converter based 4- switch three phase VSI fed PMLBDC Motor employing PI and Fuzzy control

3.2. No load condition

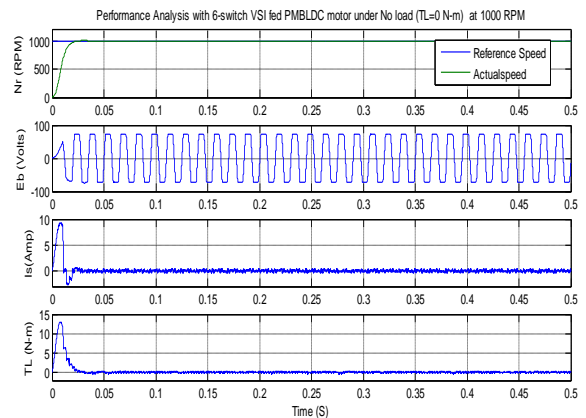

Fig13 (a) : Speed control of PI

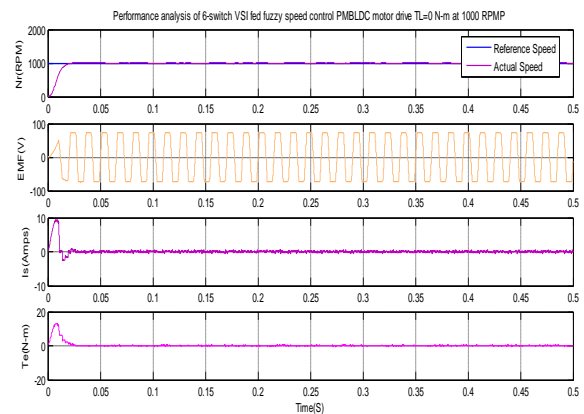

Fig13(b): Speed of Fuzzy Logical Control

Fig13: Performance characteristics of Interleaved boost converter with 6- switch VSI fed PMLBDC Motor are shown for a speed of 1000 RPM at No load ($T_L = 0$ N-m)

The PMBLDC motor with 6-switch VSI inverter at no load ($T_L=0\text{N-m}$) with a speed of 1000Rpm is considered. Fig13(a): shows the speed, back EMF, stator current and load torque is observed that actual speed of the motor is same as reference speed after the speed is pick up initially. The back EMF is 85 V. Which is trapezoidal in nature. At it is no load condition, starting current of BLDC motor is 8 Amps, then the current falls to zero as observed from current wave form. Fig13(b): shows the performance characteristics of PMBLDC motor topology with 1000Rpm at no load with fuzzy logic controller. The fuzzy logic controller follower the rule base as given in Table-2. The speed is fine turned with FLC .The stator current wave form has lower value of negative peak in case of FLC scheme.similary the torque wave form shows lower level of negative peak under no load condition.

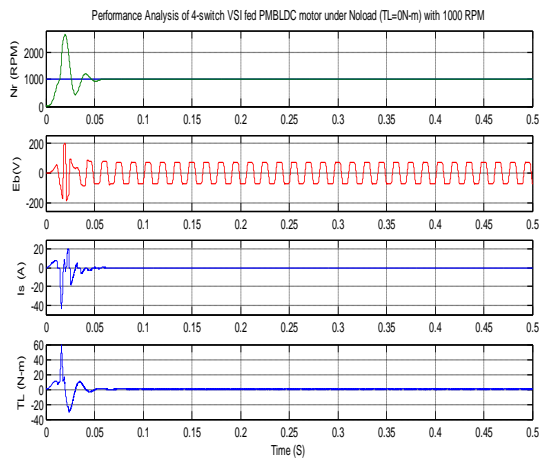

Fig14(a) :Speed control of PI

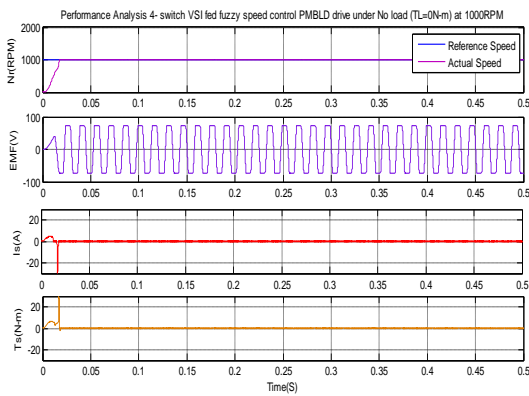

Fig14(b): Speed of Fuzzy Logical Control

Fig14:Performance characteristics of Interleaved boost converter with 4- switch VSI fed PMBLDC Motor are shown for a speed of 1000 RPM at No load ($T_L = 0 \text{ N-m}$)

Fig14: The back EMF stator current and torque initially exhibit some fluctuations but slowly settle down to steady state value. With fuzzy logic controller, the wave shapes of the performance measures are smoothened with no negative peaks or variations .In the whole in case of No load condition, fuzzy logical control of 4-switch VSI fed PMBLDC motor drive exhibits superior performance compared to its counterparts.

3.3. Application of Load

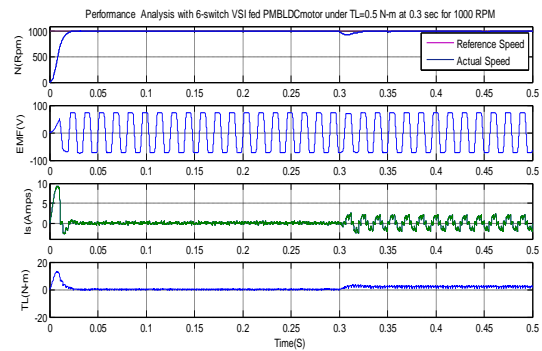

Fig15(a): Speed control of PI

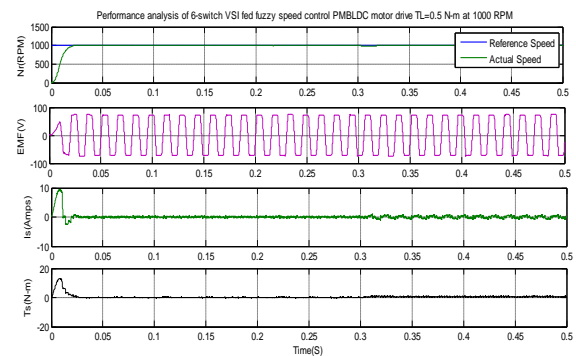

Fig15(b): Speed of Fuzzy Logical Control

Fig15: Performance characteristics of Interleaved boost converter with 6- switch VSI fed PMBLDC Motor are shown for a speed of 1000 RPM under loaded condition at 0.3secs ($T_L = 0.5 \text{ N-m}$).

Fig15(a):describes the performance characteristics of 6 switch VSI fed drive under application of load $T_L=0.5\text{N-m}$ at time instant 0.3 sec which at time instant 0.3 sec with speed 1000Rpm employing PI control the speed waveform derivate from reference value during application of load at 0.3 sec and restores to normal speed. The back EMF waveform is trapezoidal in nature and is 85V .The starting current is 9Amps. While it is 4.5Amps during loaded condition. The no load torque is 10Nm; while it is

5Nm during loaded condition. Fig 15 (b): Shows PMBLDC drives topology employing fuzzy control. It is observed that's the speed control is very smooth unlike PI control, Where the actual speed is nearly same a reference speed even after application of load at 0.3 Sec, The current and torque wave forms becomes smooth ere in case of fuzzy control.

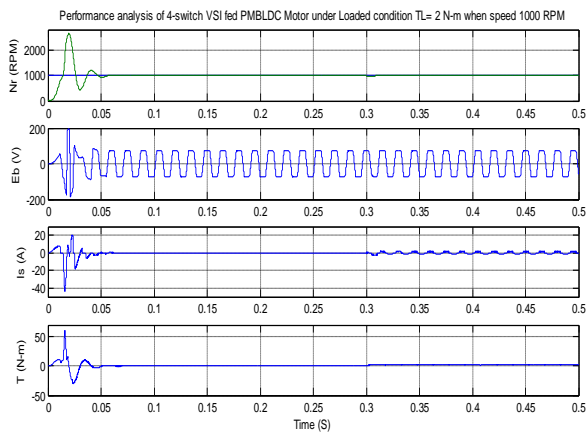

Fig16 (a): Speed control of PI

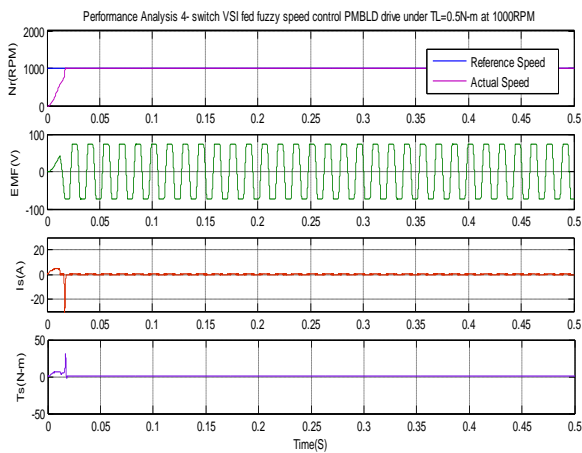

Fig16(b) :Speed of Fuzzy Logical Control

Fig16: Performance characteristics of Interleaved boost converter with **4-switch** VSI fed PMBLDC Motor are shown for a speed of 1000 RPM under load condition at 0.3secs (TL = 0.5 N-m)

With PI control in case of 4-witch cases the fluctuations are maximum at starting and gradually reduced with PI control. With the fuzzy control, the smooth control is observed with les deviations on negative side. Summarizing the above, we have for laded condition,4-switch VSI fed PMBLDC motor employing Fuzzy control exhibits better performance compared to reset of the configuration.

3.4. Dynamic response at No load condition

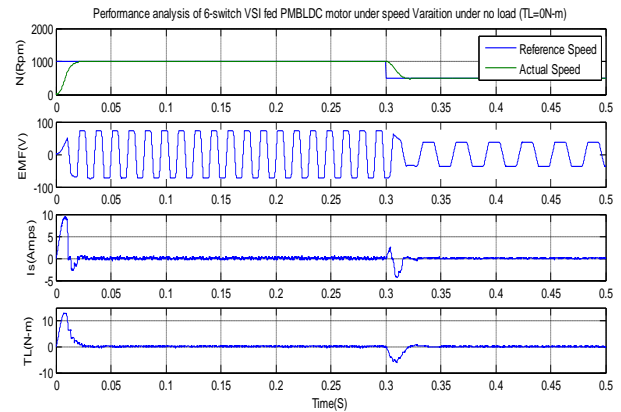

Fig17(a):Speed control of PI

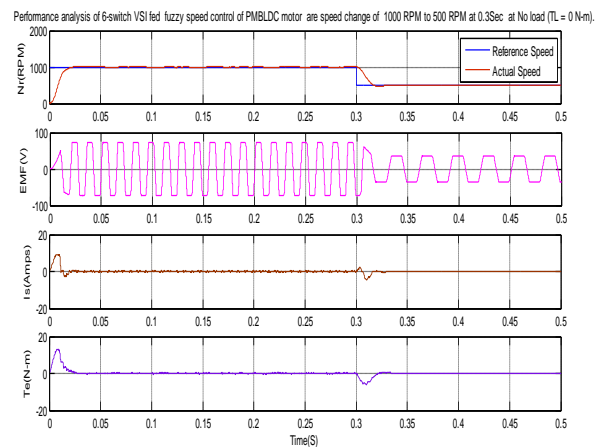

Fig17(b): Speed of Fuzzy Logical Control

Fig17: Performance characteristics of Interleaved boost converter with **6- switch** VSI fed PMBLDC Motor are shown for a speed change of 1000 RPM to 500 RPM at 0.3Sec at No load (TL = 0 N-m).

Dynamic performance of BLDC motor with speed variation from 1000Rpm at 0.3 sec is investigated in Fig17(a):and Fig17(b): respectively under no load condition the former uses PI control, while the latter employs fuzzy control. Under loaded condition, the actual speed gradually reaches to the reference speed during the dynamic performance. The back EMF waveform demonstrate variation, with 85V during no load, where as 45V in case of dynamic response. Similarly the stator current and torque fluctuate during dynamic response exhibiting considered negative peaks employing PI control. The fuzzy control variation in the performance characteristics smooth.

3.5. Dynamic response Application of Load

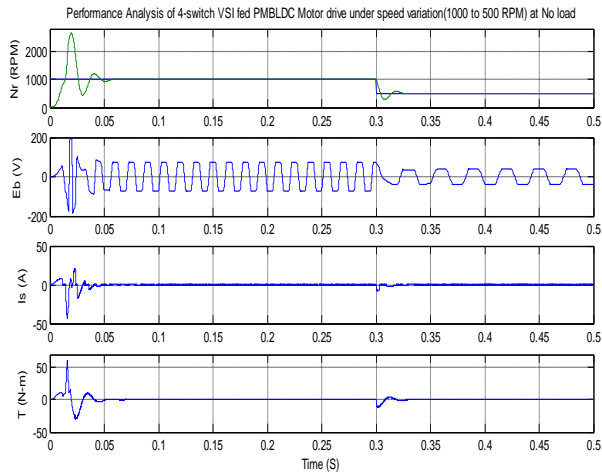

Fig18(a) :Speed control of PI

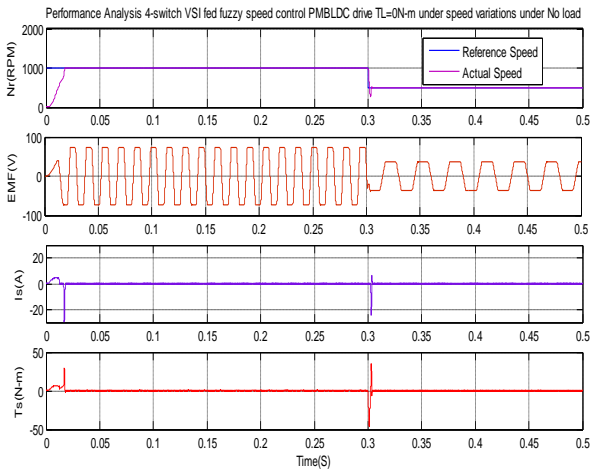

Fig18(b): Speed of Fuzzy Logical Control

Fig18: Performance characteristics of Interleaved boost converter with **4-switch** VSI fed PMBLDC Motor are shown for a speed change of 1000 RPM to 500 RPM at 0.3Sec at No load ($T_L = 0$ N-m).

Fig18(a):andFig18(b):shows Performance characteristics of Interleaved boost converter with **4-switch** VSI fed PMBLDC Motor are shown for a speed change of 1000 RPM to 500 RPM at 0.3Sec at No load .With PI control in case of 4-switch configuration the fluctuation during dynamic response are reduced when compared to 6-switch configuration with PI control. Further using fuzzy logical control ,4-switch configuration exhibits significantly better performance when compared PI control and also 6-switch based configuration with Fuzzy and PI controllers.

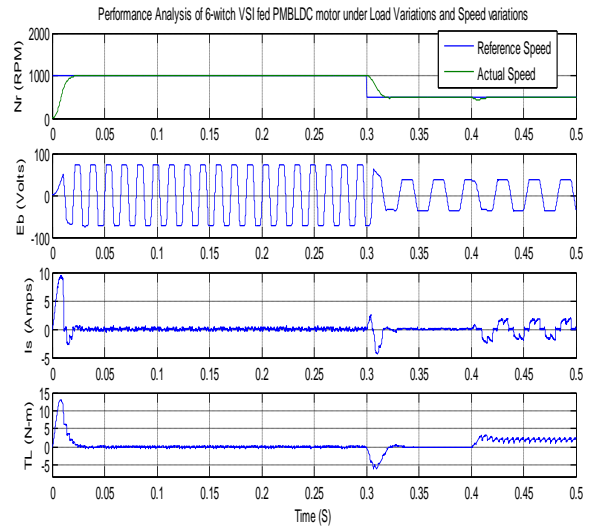

Fig19(a): Speed control of PI

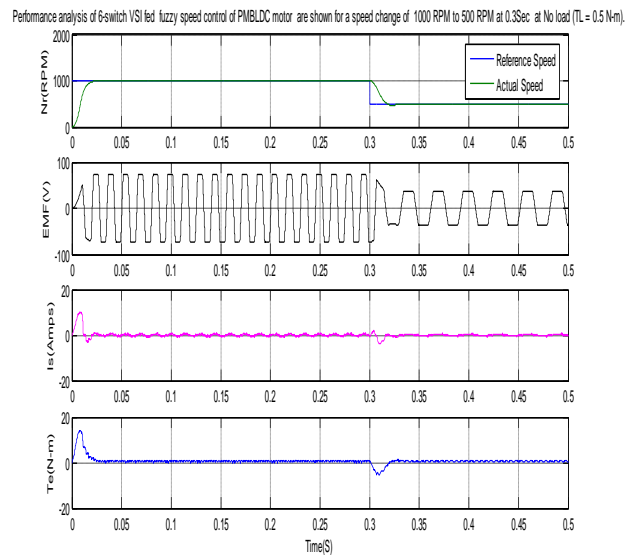

Fig19(b): Speed of Fuzzy Logical Control

Fig19:Performance characteristics of Interleaved boost converter with **6- switch** VSI fed PMBLDC Motor are shown for a speed change of 1000 RPM to 500 RPM at 0.3Sec under loaded condition ($T_L = 0.5$ N-m).

Fig19:In case of with 6-switch configuration PI control during dynamic performance under loaded condition, the fluctuation in stator current and torque are maximum among all configuration. with Fuzzy control, the deviations are reduced. In case of 4-switch configuration with PI control the fluctuation in the performance measures are less .

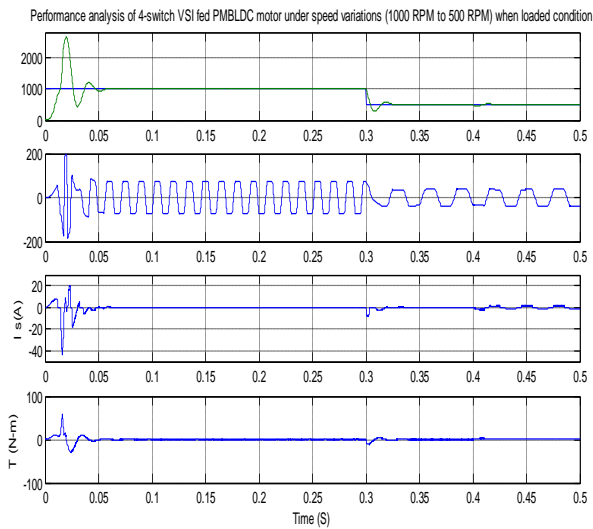

Fig20 (a): Speed control of PI

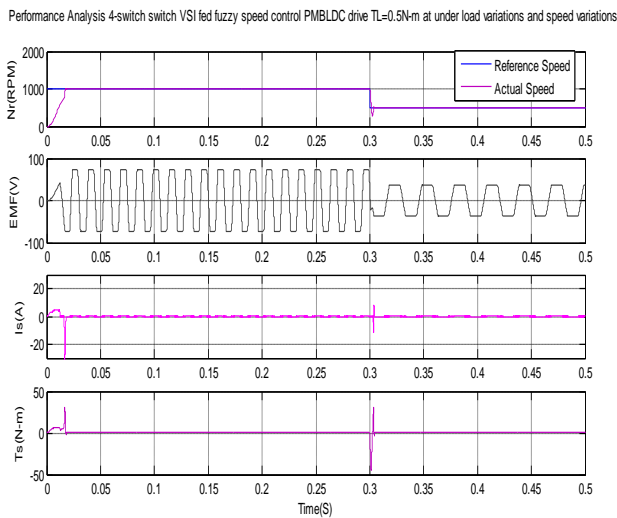

Fig20(b): Speed of Fuzzy Logical Control

Fig20: Performance characteristics of Interleaved boost converter with **4-switch** VSI fed PMBLDC Motor are shown for a speed change of 1000 RPM to 500 RPM at 0.3Sec under loaded condition ($T_L = 0.5 \text{ N-m}$).

Fig20(a): and Fig20(b): When compared 6-switch configuration. Further with deployment of Fuzzy logical, the deviations are further mitigated and fine control of speed is achieved. In a nutshell 4-switch configuration is better compared to 6-switch configuration in terms of speed control and fluctuation in stator current and torque. In other words, 4-switch configuration with Fuzzy control ideal for efficient and smooth speed control.

4. Conclusion

Soft switching of interleaved boost converter with 4 switch configuration and 6 switch configuration based VSI fed PMBLDC motor was developed in this paper. The performance evaluation of the above mentioned topologies are studied and analyzed under different operating conditions. The results, shows that 4-switch configuration with Fuzzy control is proved to be more effective than 6-switch converter based drive in term of fine control and tuning, minimizing of fluctuation in stator current and output torque ripple etc.

References

1. Ching-Ming Lai, Ming-Ji Yang and Shih-Kun Liang, "A Zero Input Current Ripple ZVS/ZCS Boost Converter with Boundary-Mode Control," 2014, 7, 6765-6782; doi:10.3390/en7106765, ISSN 1996-1073.
2. Y.-C. Hsieh, T.-C. Hsueh, and H.-C. Yen, "An interleaved boost converter with zero-voltage transition," *IEEE Trans. Power Electron.*, vol. 24, no. 4, pp. 973–978, Apr. 2009.
3. J. Yungtaek and M. M. Jovanovic, "Interleaved PFC boost converter with intrinsic voltage-doubler characteristic," in *Proc. IEEE Power Electron. Spec. Conf.*, Jun. 2006, pp. 1888–1894.
4. H. M. Suryawanshi, M. R. Ramteke, K. L. Thakre, and V. B. Borghate, "Unity-power-factor operation of three-phase AC–DC soft switched converter based on boost active clamp topology in modular approach," *IEEE Trans. Power Electron.*, vol. 23, no. 1, pp. 229–236, Jan. 2008.
5. Yie-Tone Chen, Shin-Ming Shiu, and Ruey-Hsun Liang, "Analysis and Design of a Zero-Voltage-Switching and Zero-Current-Switching Interleaved Boost Converter," *IEEE Transactions ON Power Electronics*, VOL. 27, no. 1, Jan. 2012.
6. Arango, E.; Ramos-Paja, C.A.; Calvente, J.; Giral, R.; Serna-Garces, S.I. Asymmetrical interleaved DC/DC switching converters for photovoltaic and fuel cell applications—Part 2: Control-oriented Models. *Energies* 2013, 6, 5570–5596.
7. G. Yao, A. Chen, and X. He, "Soft switching circuit for interleaved boost converters," *IEEE Trans. Power Electron.*, vol. 22, no. 1, pp. 80–86, Jan. 2007.
8. Pragsen Pillay and R. Krishnan, "Modeling, simulation and analysis of permanent-magnet motor drives. II. The brushless DC motor drive", *IEEE Transactions on Industrial Electronics*, vol. 25, no. 2, pp. 274 – 279, Mar/Apr 1989.

9. R. Madhusudhanan, S. Rama Reddy "Digital Simulation of ZVSDC to DC Converter using Simulink" *Journal of Electrical Engineering*, Volume 8/2008 Edition -4
10. Tan C.S., Baharuddin I. "Study of Fuzzy and PI controller for permanent magnet brushless dc motor drive". *Proceedings of International Power Engineering and Optimization Conference*, June 23-24, 2010, pp.517-521.
11. V. Ramesh, Y. Kusuma Latha "A Soft Switching Control Strategy Based on Interleaved Boost Converter for BLDC Motor Drive" *International Journal of Power Electronics and Drive Systems*. Vol 6, No 3, September 2015. ISSN: 2088-8694.
12. B. Singh, B. N. Singh, A. Chandra, K. Al-Haddad, A. Pandey and D. P. Kothari, "A review of single-phase improved power quality AC-DC converters," *IEEE Trans. Industrial Electron.*, vol. 50, no. 5, pp. 962 – 981, oct. 2003.
13. Y.W. Lo and R. J. King, "High performance ripple feedback for the buck unity-power-factor rectifier," *IEEE Trans. Power Electron*, vol. 10, pp. 158-163, March 1995.
14. M. Daniele, P.K. Jain and G. Joos "A single-stage power-factor corrected AC/DC converter," *IEEE Trans. Power Electron.*, vol. 14, pp. 1046 -1055, Nov 1999.
15. D. Chandra Sekhar and G.V. Marutheshwar "Modeling and Direct Torque Control of Induction Motor by Using Fuzzy Logic Control Technique" *Journal of Electrical Engineering*, Volume 15/2015-Edition